

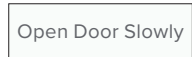

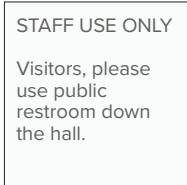

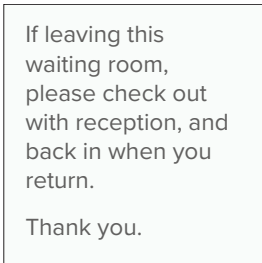
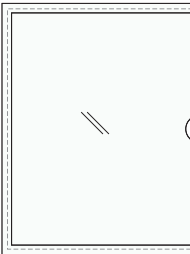
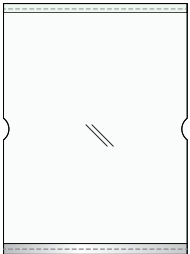

5.02		Sign Family Overview
5.04	IN.01	Informational, Small
5.05	IN.02	Informational, Medium
5.06	IN.03	Informational, Large
5.07	IN.03	Additional Layouts
5.08	IN.10	Insert Holder, Letter Size
5.09	IN.10A	Insert Holder, Letter Size, Room Sign Add-On
5.10	IN.10B	Insert Holder, Half Letter Size
5.11	IN.11	Insert Holder, Laminated Letter Size
5.12	IN.12	Insert Holder, Tabloid Size
5.13	IN.13	Insert Holder, Poster Size
5.14	IN.20	Red-Green Slider
5.15	IN.21	Patient Room Status Flags
5.16	IN.30	No Food or Drink
5.17	IN.31	No Photos or Video
5.18	IN.32	Healing Environment: Recording and Noise
5.19	IN.33	Video Surveillance
5.20	IN.34	Chicken Pox or Rash Warning
5.21	IN.35	No Feeding the Squirrels
5.22	IN.36	Take Personal Belongings

				
<p>IN.01 Informational, Small</p>	<p>IN.02 Informational, Medium</p>	<p>IN.03 Informational, Large</p>	<p>IN.10 Insert Holder, Letter Size</p>	<p>IN.10A Insert Holder, Letter Size Room Sign Add-On</p>
				
<p>IN.10B Insert Holder, Half Letter Size</p>	<p>IN.11 Insert Holder, Laminated Letter Size</p>	<p>IN.12 Insert Holder, Tabloid Size</p>	<p>IN.13 Insert Holder, Poster Size</p>	
				
<p>IN.20 Red-Green Slider</p>	<p>IN.21 Patient Room Status Flags</p>	<p>IN.30 No Food or Drink</p>	<p>IN.31 No Photos or Video</p>	<p>IN.32 Healing Environment: No Recording and Noise</p>

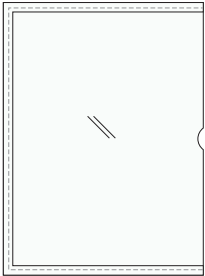
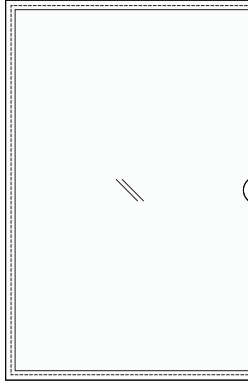
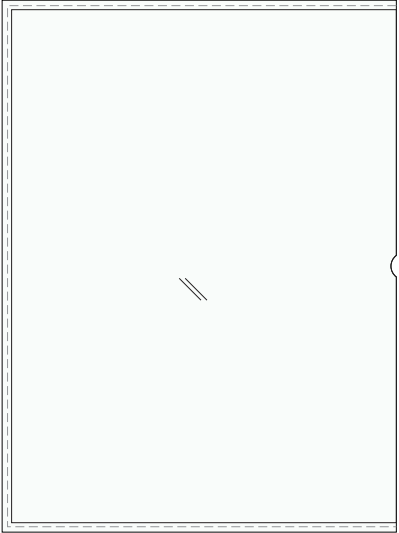

IN.33
Video Surveillance

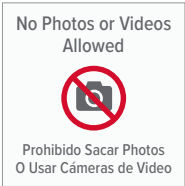
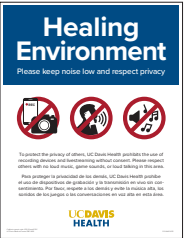
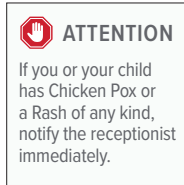

IN.34
Chicken Pox or Rash Warning



IN.35
No Feeding the Squirrels

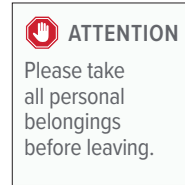

IN.36
Take Personal Belongings

Informational

IN.01

Informational, Small

Usage

- This sign type is used where information needs to be posted.
- Messages shown are for example/placement only.

Placement

- Placed on walls or doors as needed.

Components

- (A) Panel: 1/8" thick non-glare acrylic
 - Finish: subsurface painted
 - Sides: no paint with clean routed edges
- (B) Graphics: subsurface UV cured digital print
 - Typeface: Proxima Nova Regular

Colors & Materials

References as noted below. See Chapter 1: Universal Standards for specifications.

(C1) White Wonder

(D3) PMS Cool Gray 10C

Installation

- See Appendix A, Drawing FD.10 for approved standard fabrication and installation detail.

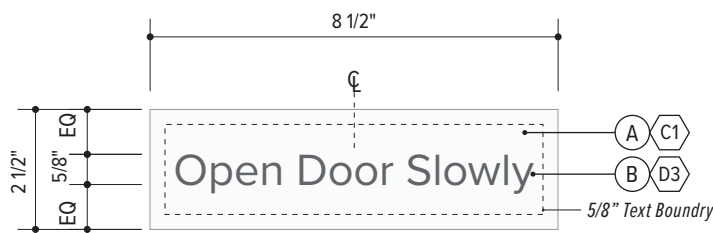

Front View
Scale: 3"=1'-0"



Side

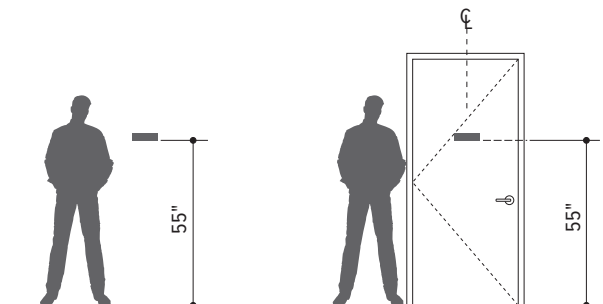

Installation Context - Wall
Scale: 3/16" = 1'-0"

Installation Context - Door
Scale: 3/16" = 1'-0"

Informational

IN.02

Informational, Medium

Usage

- This sign type is used where information needs to be posted.
- Messages shown are for example/placement only.

Placement

- Placed on walls or doors as needed.

Components

- (A) Panel: 1/8" thick non-glare acrylic
 - Finish: subsurface painted
 - Sides: no paint with clean routed edges
- (B) Graphics: subsurface UV cured digital print
 - Typeface: Proxima Nova Regular

Colors & Materials

References as noted below. See Chapter 1: Universal Standards for specifications.

(C1) White Wonder

(D3) PMS Cool Gray 10C

Installation

- See Appendix A, Drawing FD.10 for approved standard fabrication and installation detail.

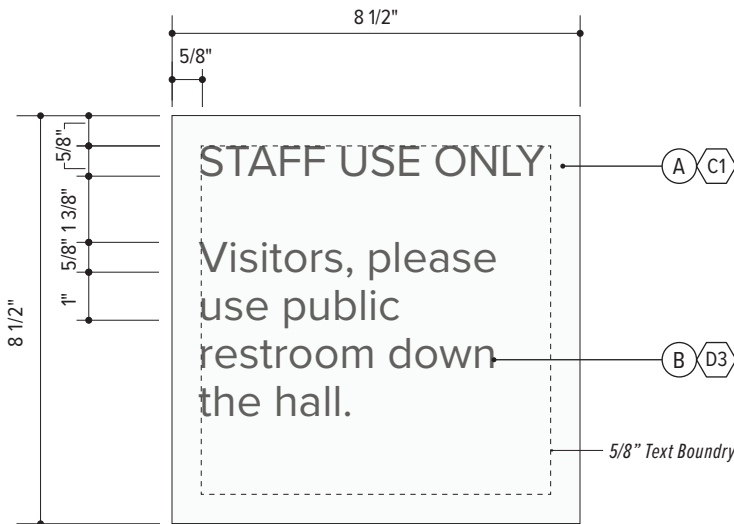

Front View
Scale: 3"=1'-0"



Side

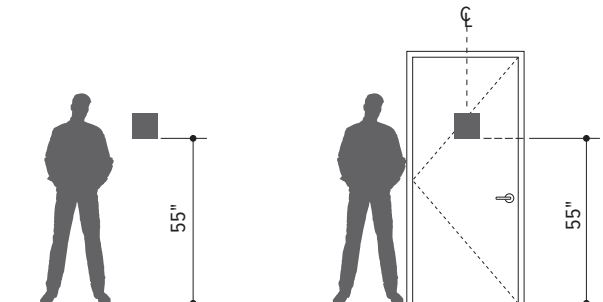

Installation Context - Wall
Scale: 3/16" = 1'-0"

Installation Context - Door
Scale: 3/16" = 1'-0"

Informational

IN.03

Informational, Large

Usage

- This sign type is used where information needs to be posted. Messages shown are for example/ placement only.

Placement

- Placed on walls or doors as needed.

Components

- (A) Panel: 1/8" thick non-glare acrylic
 - Finish: subsurface painted
 - Sides: no paint with clean routed edges
- (B) Graphics: subsurface UV cured digital print
 - Typeface: Proxima Nova Regular

Colors & Materials

References as noted below. See Chapter 1: Universal Standards for specifications.

(C1) White Wonder

(D3) PMS Cool Gray 10C

Installation

- See Appendix A, Drawing FD.10 for approved standard fabrication and installation detail.

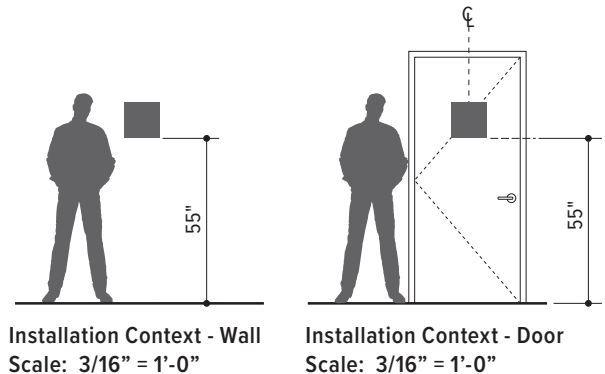
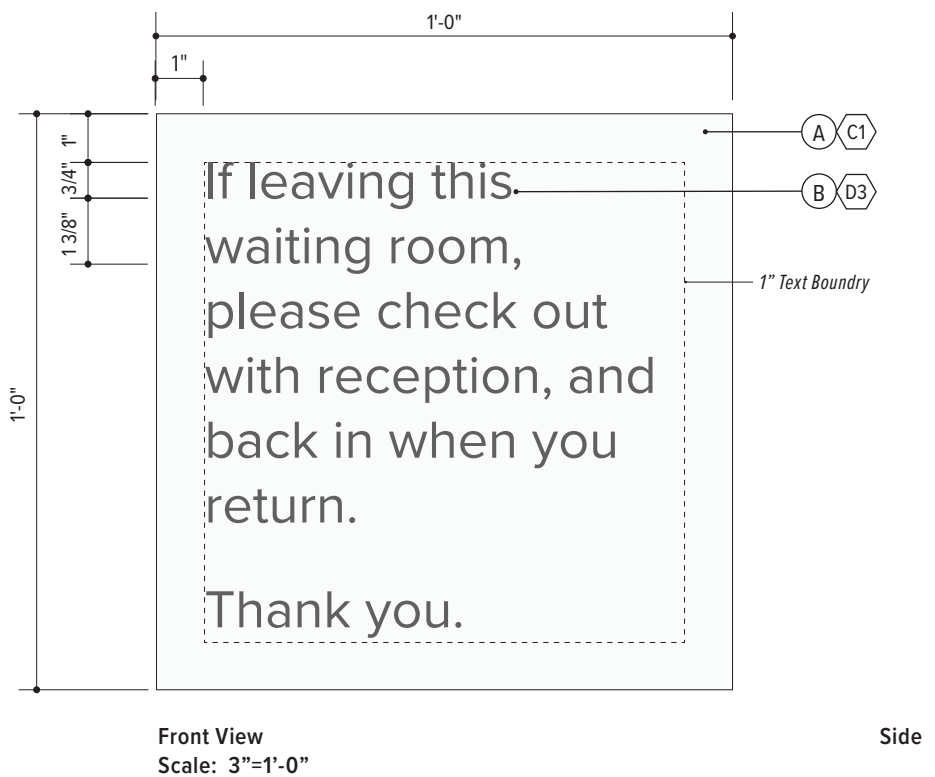

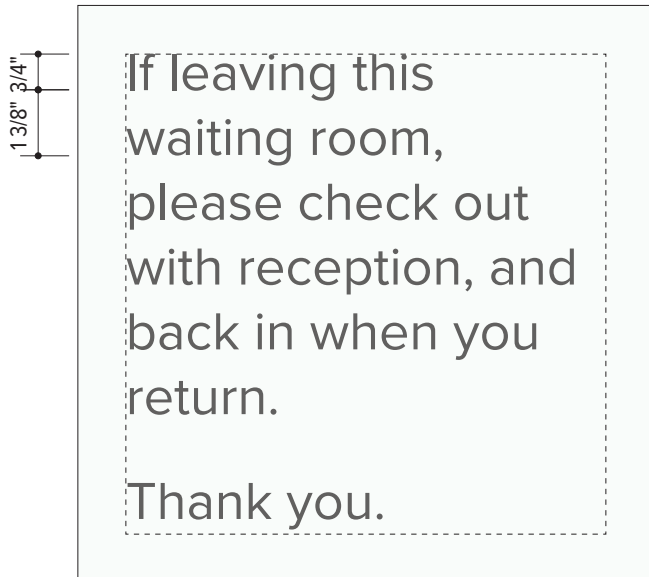

3/4" H Copy

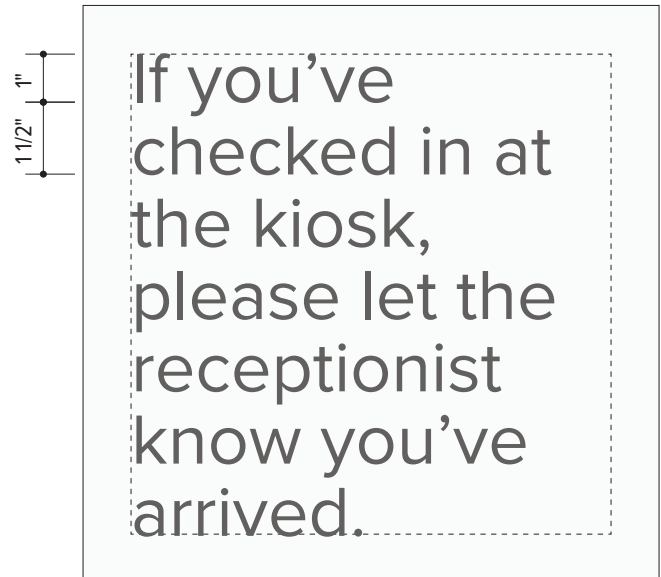

1" H Copy

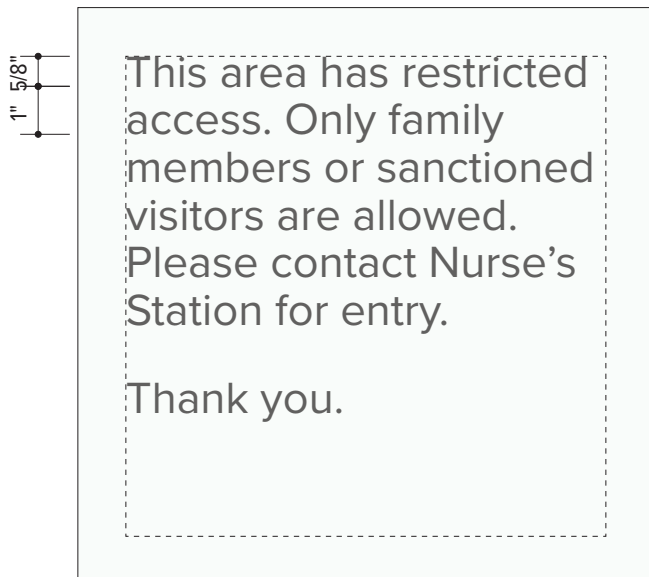

5/8" H Copy

Informational

IN.10

Insert Holder, Letter Size

Usage

- This sign type is used when the end user will need an insert holder for flexible inserts that they will manage.
- Consultant to verify the need for this insert holder size with the end user as every department's needs are unique.

Placement

- To be coordinated with end user.
- Installed in vertical or horizontal format, as needed by end user.

Components

- (A) Back Panel: 3/16" thick acrylic backer, with milled out pocket (smooth edges with no visible milled markings) and routed thumb notch
 - Finish: subsurface painted
 - Sides: no paint with clean routed edges

- (B) Front Panel: 1/8" thick non-glare acrylic lens with routed thumb notch
 - Finish: subsurface painted border on three sides to conceal spacers beneath
 - Window left clear
- (C) Insert: 8 1/2" x 11" letter size insert by others

Colors & Materials

References as noted below. See Chapter 1: Universal Standards for specifications.

(C1) White Wonder

(M1) Non-glare Acrylic

Installation

- See Appendix A, Drawing FD.26 for approved standard fabrication and installation detail.

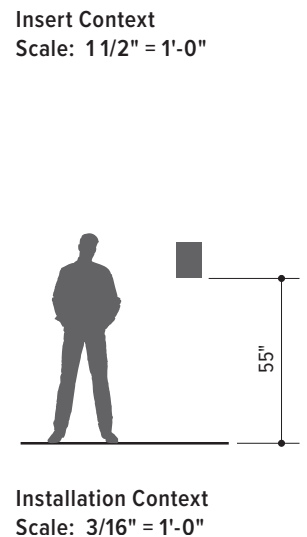
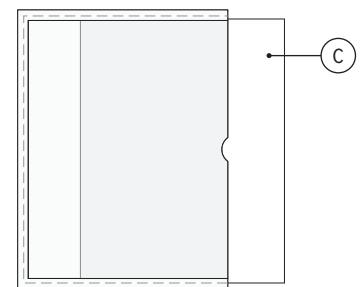
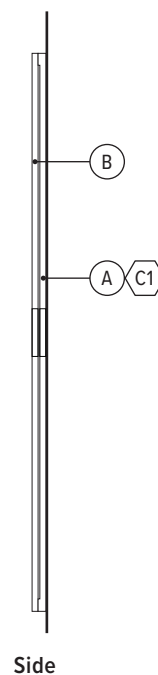
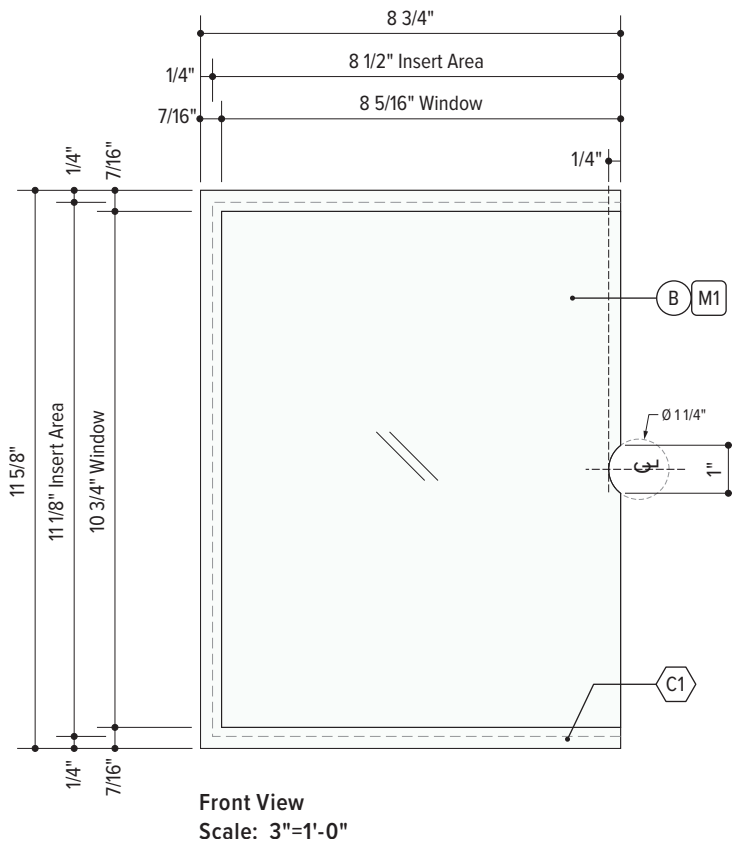

Informational

IN.10A

Insert Holder, Letter Size, Room Sign Add-On

Usage

- This sign type is used when the end user will need an insert holder for flexible inserts that they will manage.

Placement

- Placed centerline with corresponding room identification sign, 1" below.

Components

- (A) Back Panel: 3/16" thick acrylic backer, with milled out pocket (smooth edges with no visible milled markings) and routed thumb notch
 - Finish: subsurface painted
 - Sides: no paint with clean routed edges
- (B) Front Panel: 1/8" thick non-glare acrylic lens with routed thumb notch
 - Finish: subsurface painted border on top to conceal spacer beneath
 - Window left clear
- (C) Aluminum Laminate: 1/16" thick
 - Finish: satin brushed horizontal grain with eased edges
- (D) Insert: 8 1/2" x 11" letter size insert by others

Additional Signs Required

- ID.20 or ID.21 Tactile Room ID

Colors & Materials

References as noted below. See Chapter 1: Universal Standards for specifications.

- (C1) White Wonder
- (M3) Brushed Aluminum
- (M1) Non-glare Acrylic

Installation

- See Appendix A, Drawing FD.26 for approved standard fabrication and installation detail.

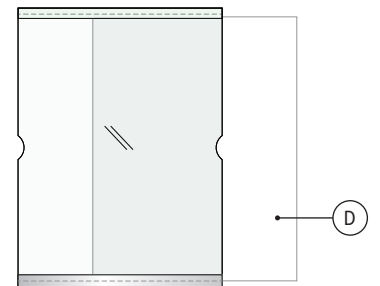
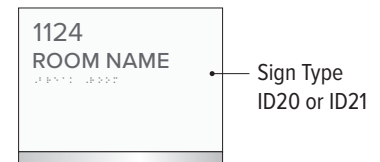
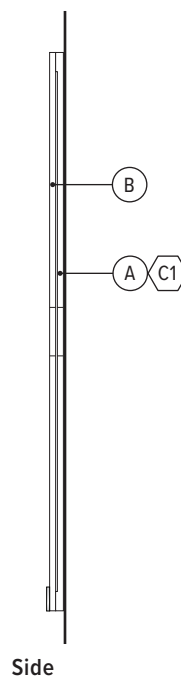
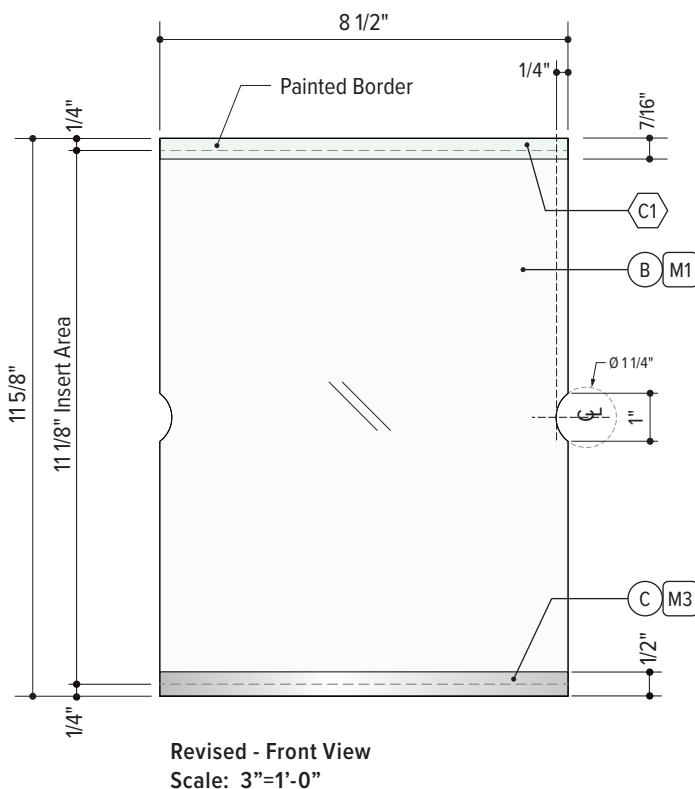

Insert Context
Scale: 1 1/2" = 1'-0"

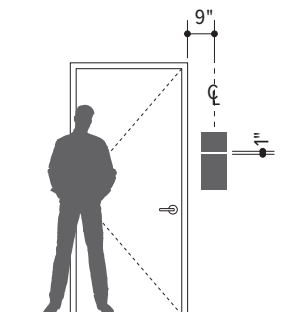

Installation Context
Scale: 3/16" = 1'-0"

Informational

IN.10B

Insert Holder, Half Letter Size

Usage

- This sign type is used when the end user will need an insert holder for flexible inserts that they will manage.

Placement

- Placed centerline with corresponding room identification sign, 1" above.

Components

- (A) Back Panel: 3/16" thick acrylic backer, with milled out pocket (smooth edges with no visible milled markings) and routed thumb notch
 - Finish: subsurface painted
 - Sides: no paint with clean routed edges
- (B) Front Panel: 1/8" thick non-glare acrylic lens with routed thumb notch
 - Finish: subsurface painted border on top to conceal spacer beneath
 - Window left clear
- (C) Aluminum Laminate: 1/16" thick
 - Finish: satin brushed horizontal grain with eased edges
- (D) Insert: 8 1/2" x 6" printed paper insert by others

Colors & Materials

References as noted below. See Chapter 1: Universal Standards for specifications.

- (C1) White Wonder
- (M1) Non-glare Acrylic
- (M3) Brushed Aluminum

Installation

- See Appendix A, Drawing FD.26 for approved standard fabrication and installation detail.

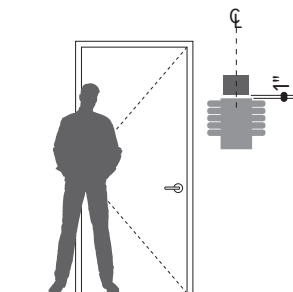
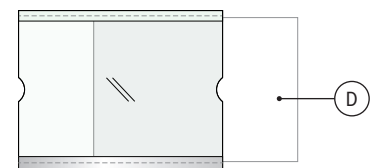
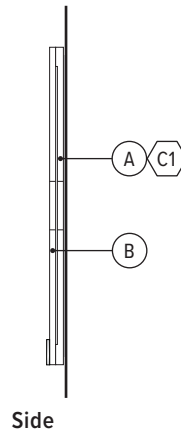
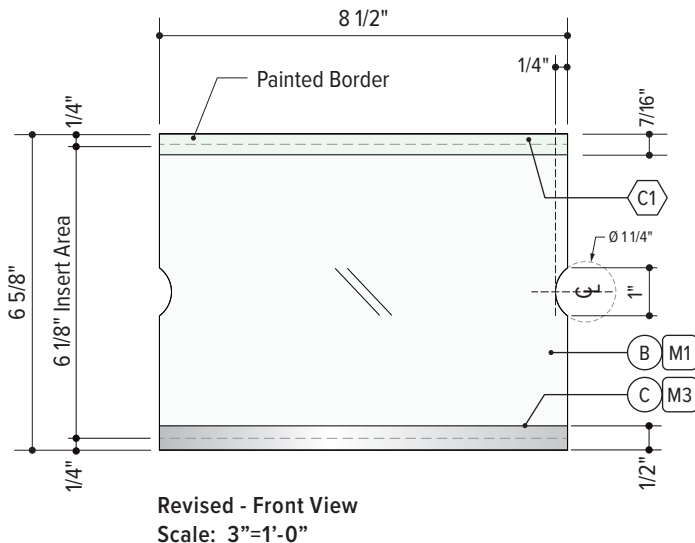

Informational

IN.11

Insert Holder, Laminated Letter Size

Usage

- This sign type is used when the end user will need an insert holder for laminated letter size inserts that they will manage.
- Laminated printouts are often provided to nursing staff by infection control or other entities as required postings at individual patient rooms.

Placement

- To be coordinated with end user.
- Installed in vertical or horizontal format, as needed by end user.

Components

- Ⓐ Back Panel: 3/16" thick acrylic backer, with milled out pocket (smooth edges with no visible milled markings) and routed thumb notch
 - Finish: subsurface painted
 - Sides: no paint with clean routed edges

- Ⓑ Front Panel: 1/8" thick non-glare acrylic lens with routed thumb notch
 - Finish: subsurface painted border on three sides to conceal spacers beneath
 - Window left clear
- Ⓒ Insert: prelaminated 8 1/2" x 11" printed paper insert by others, typical prelaminated dimensions are 9" x 12"

Colors & Materials

References as noted below. See Chapter 1: Universal Standards for specifications.

Ⓒ1 White Wonder

Ⓜ1 Non-glare Acrylic

Installation

- See Appendix A, Drawing FD.26 for approved standard fabrication and installation detail.

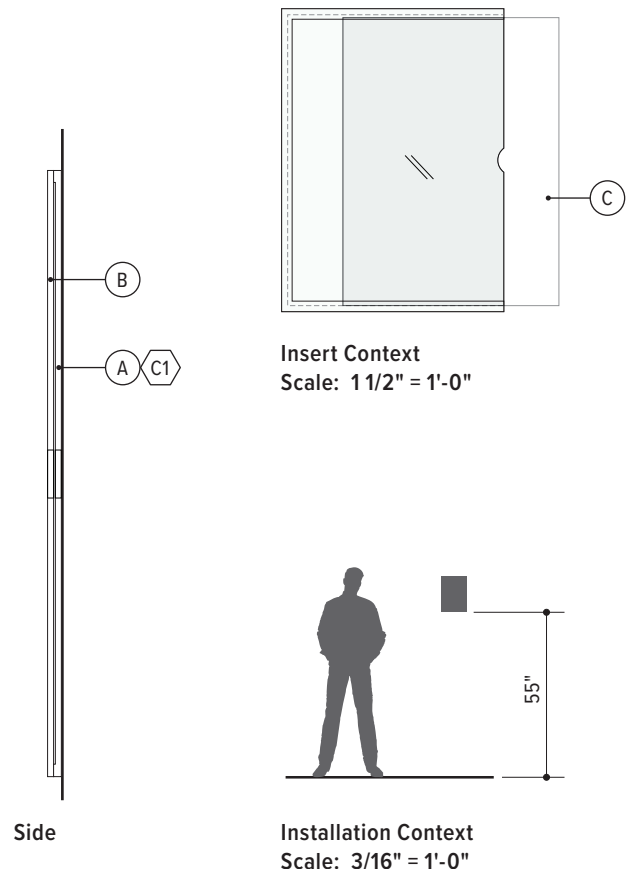
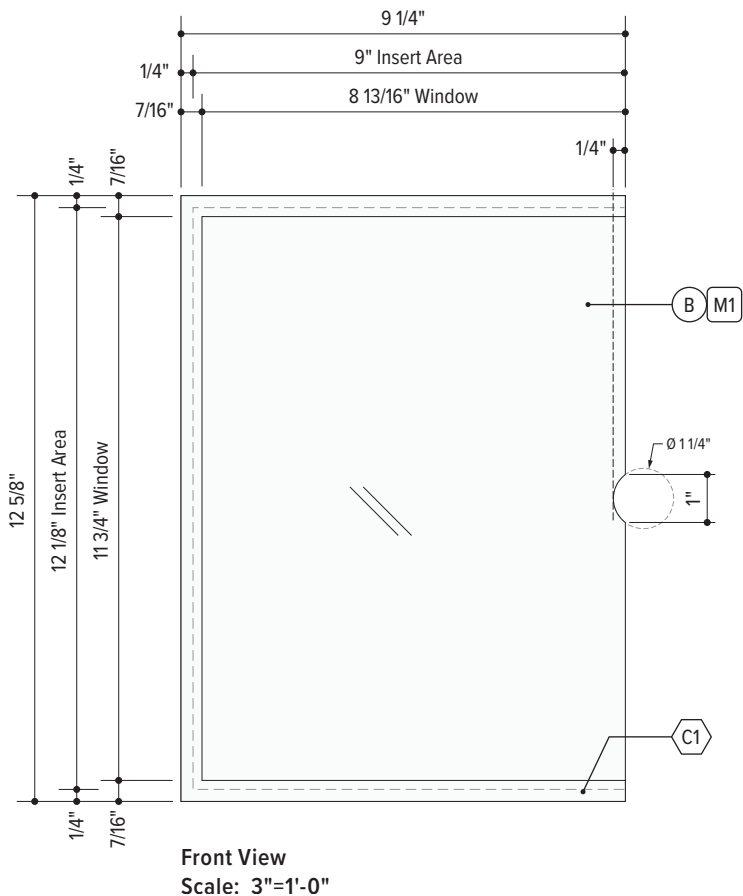

Informational

IN.12

Insert Holder, Tabloid Size

Usage

- This sign type is used when the end user will need an insert holder for flexible inserts that they will manage.
- Consultant to verify the need for this insert holder size with the end user as every department's needs are unique.

Placement

- To be coordinated with end user.
- Installed in vertical or horizontal format, as needed by end user.

Components

- (A) Back Panel: 3/16" thick acrylic backer, with milled out pocket (smooth edges with no visible milled markings) and routed thumb notch

- Finish: subsurface painted
- Sides: no paint with clean routed edges
- (B) Front Panel: 1/8" thick non-glare acrylic lens with routed thumb notch
- Finish: subsurface painted border on three sides to conceal spacers beneath
- Window left clear
- (C) Insert: 11" x 17" tabloid size insert by others

Colors & Materials

References as noted below. See Chapter 1: Universal Standards for specifications.

(C1) White Wonder

(M1) Non-glare Acrylic

Installation

- See Appendix A, Drawing FD.26 for approved standard fabrication and installation detail.

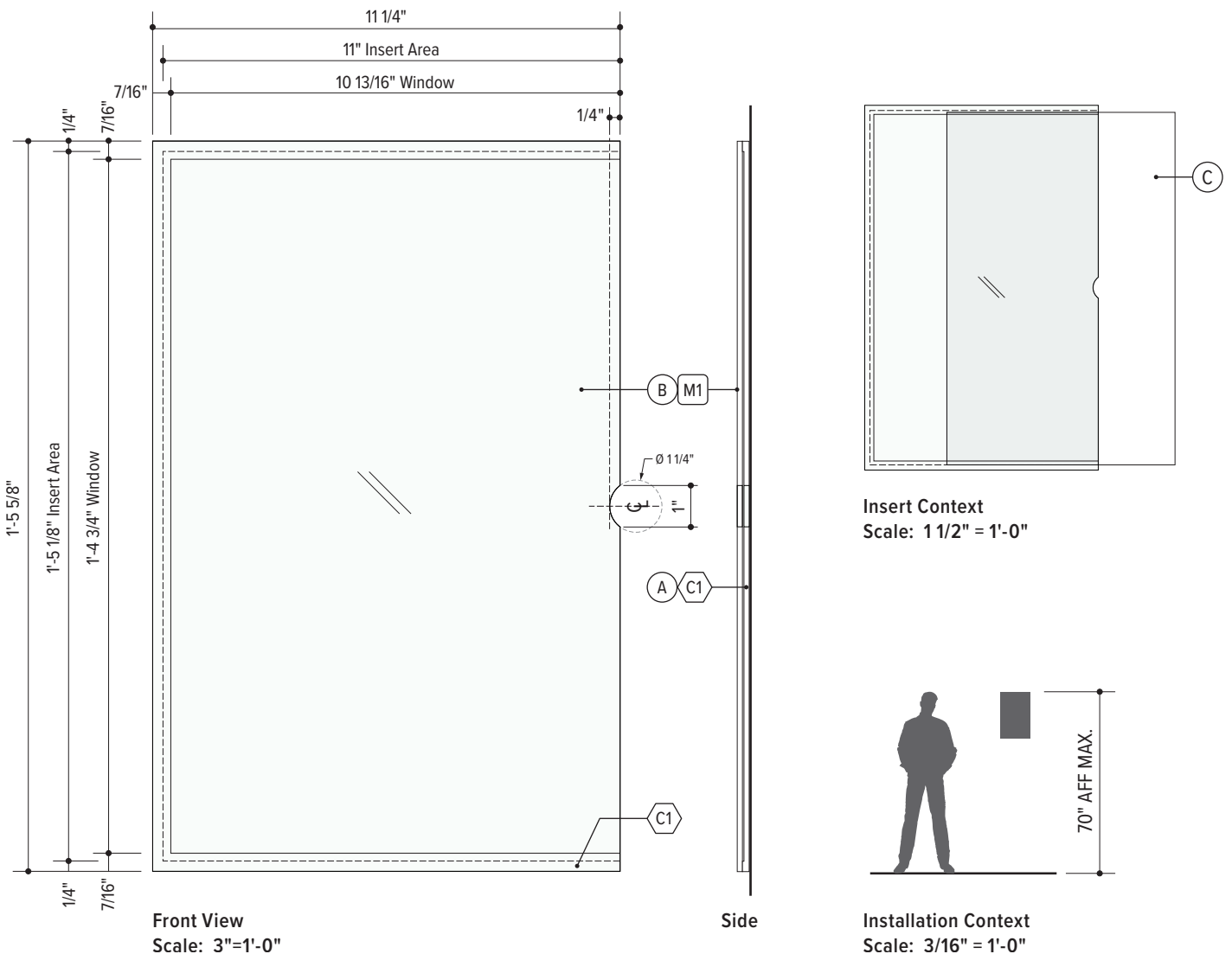

Informational

IN.13

Insert Holder, Poster Size

Usage

- This sign type is used when the end user will need an insert holder for flexible inserts that they will manage.
- Consultant to verify the need for this insert holder size with the end user as every department's needs are unique.

Placement

- To be coordinated with end user.
- Installed in vertical or horizontal format, as needed by end user.

Components

- Ⓐ Back Panel: 3/16" thick acrylic backer, with milled out pocket (smooth edges with no visible milled markings) and routed thumb notch
 - Finish: subsurface painted
 - Sides: no paint with clean routed edges

- Ⓑ Front Panel: 1/8" thick non-glare acrylic lens with routed thumb notch
 - Finish: subsurface painted border on three sides to conceal spacers beneath
 - Window left clear
- Ⓒ Insert: 18" x 24" poster size insert by others

Colors & Materials

References as noted below. See Chapter 1: Universal Standards for specifications.

Ⓒ1 White Wonder

Ⓜ1 Non-glare Acrylic

Installation

- See Appendix A, Drawing FD.26 for approved standard fabrication and installation detail.

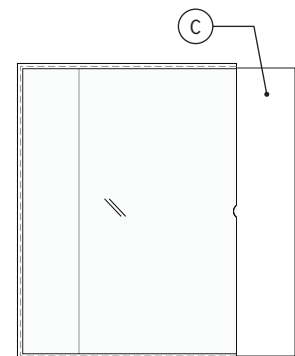
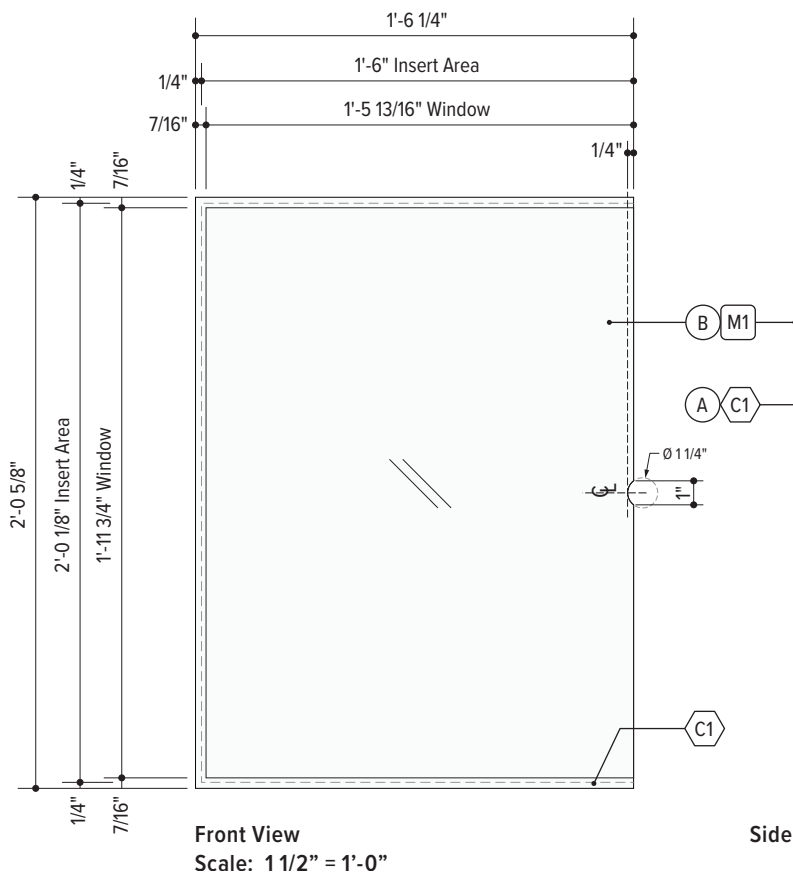

Insert Context
Scale: 3/4" = 1'-0"



Installation Context
Scale: 3/16" = 1'-0"

Usage

- This sign type is a supplemental accent for standard room identification signs.
- The inclusion of the slider is at the discretion of the end user.
- The green/red could mean different things to different departments, and should be verified with the end user based on their operational needs.

Placement

- Sign is to be placed below a standard room sign, center aligned.

Components

- (A) Corresponding room sign programmed separately
- (B) Aluminum Laminate: 1/16" thick adhered to spacers
 - Finish: satin brushed horizontal grain with eased edges

- (C) Slider Panel: .060" thick non-glare acrylic
 - Finish: subsurface painted
 - Sides: no paint with clean routed edges
- (D) Spacers: .090" thick clear spacers to create opening for slider panel and stopper so the slider panel cannot be easily removed
- (E) Back Panel: 1/8" thick non-glare acrylic panel
 - Sides: clear with clean routed edges
 - Graphics: subsurface UV cured digital print

Colors & Materials

References as noted below. See Chapter 1: Universal Standards for specifications.

- (C1) White Wonder
- (D6) Emergency Red
- (D9) Regulatory Green
- (M3) Brushed Aluminum

Installation

- See Appendix A, Drawing FD.16 for approved standard fabrication and installation detail.

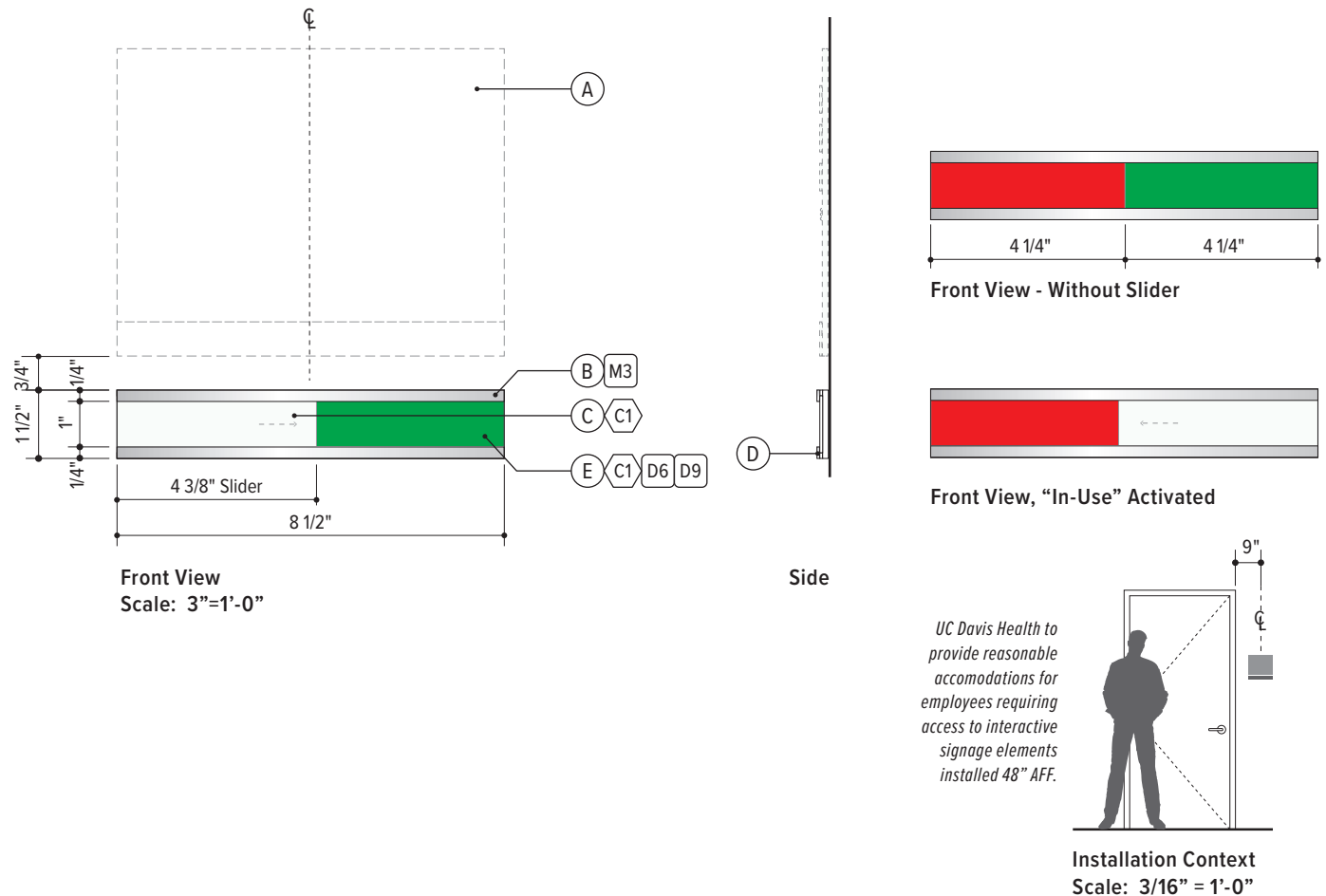

Informational

IN.21

Patient Room Status Flags

Usage

- When requested by the end user, this sign type is paired with the room identification sign.
- This sign is typically used when the red-green slider is not enough, and the Patient Precaution Sign is too robust.

Placement

- Sign is to be placed on walls 4" above the corresponding room sign.

Components

- Ⓐ Omnimed Standard 4" 6-Flag System, Part#291708

Installation

- Mounted mechanical fasteners as required for flush installation, and as recommended by manufacturer.

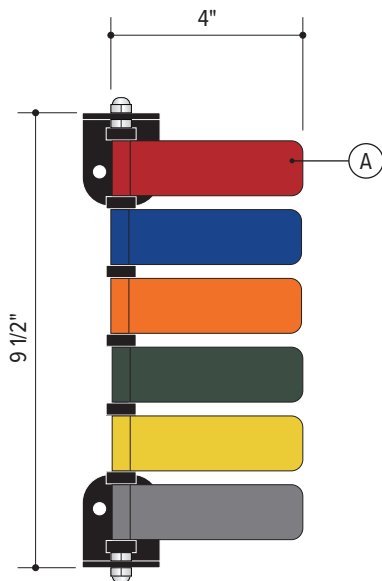

Front View
Scale: 3"=1'-0"

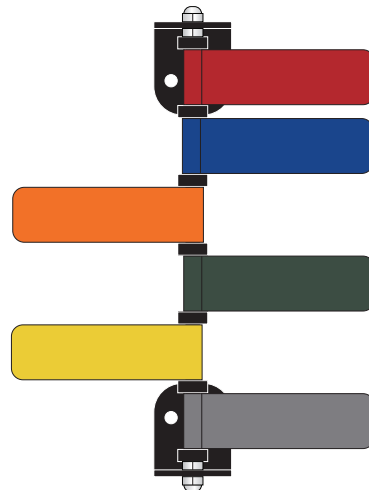

Activated

UC Davis Health to provide reasonable accommodations for employees requiring access to interactive signage elements installed 48" AFF.

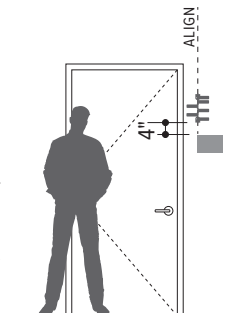

Installation Context
Scale: 3/16" = 1'-0"

Informational

IN.30

No Food or Drink

Usage

- This sign type is used to identify a room or area where no food or drinks are allowed
- Sign Consultant to verify with end-user which No Food or Drink layout to use based on their specific needs.

Placement

- Place adjacent to the affected room/area entrance or within the space in a visible position.

Components

- (A) Panel: 1/8" thick non-glare acrylic
 - Finish: subsurface painted
 - Sides: no paint with clean routed edges

- (B) Graphics: subsurface UV cured digital print
 - Typeface: Proxima Nova Condensed Medium

Colors & Materials

References as noted below. See Chapter 1: Universal Standards for specifications.

- (C1) White Wonder
- (D3) PMS Cool Gray 10C
- (D6) Emergency Red

Installation

- See Appendix A, Drawing FD.10 for approved standard fabrication and installation detail.

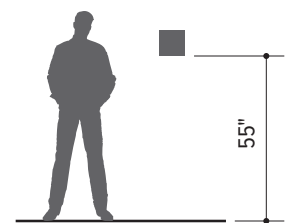

Installation Context
Scale: 3/16" = 1'-0"

Informational

IN.31

No Photos or Video

Usage

- This sign type is used to identify a room or area where no photos or videos are allowed, such as a department sub-waiting area.

Placement

- Place adjacent to the affected room/area entrance or within the space in a visible position.

Components

- (A) Panel: 1/8" thick non-glare acrylic
 - Finish: subsurface painted
 - Sides: no paint with clean routed edges
- (B) Graphics: subsurface UV cured digital print
 - Typeface: Proxima Nova Condensed Medium

Colors & Materials

References as noted below. See Chapter 1: Universal Standards for specifications.

- (C1) White Wonder (D3) PMS Cool Gray 10C (D6) Emergency Red

Installation

- See Appendix A, Drawing FD.10 for approved standard fabrication and installation detail.

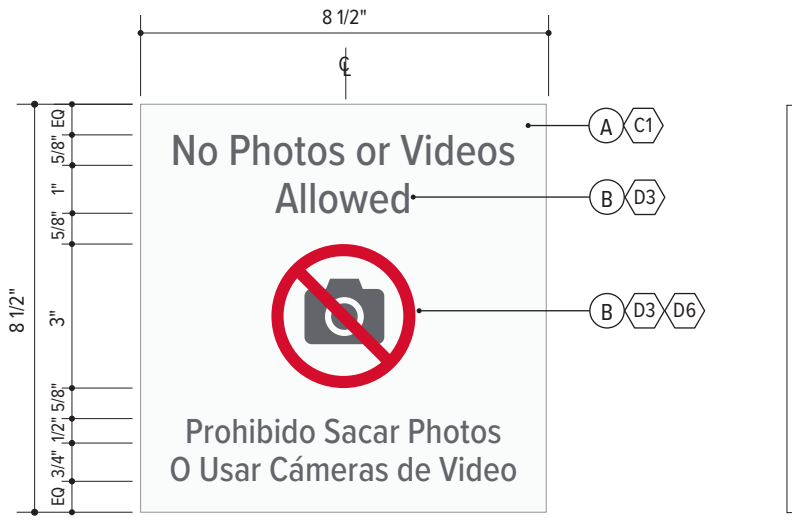

Front View
Scale: 3"=1'-0"

Side

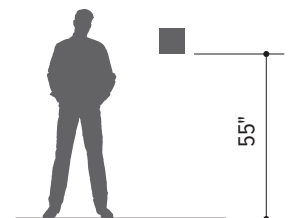

Installation Context
Scale: 3/16" = 1'-0"

Informational

IN.32

Healing Environment: Recording and Noise

Usage

- This sign type is used to identify a room or area where no recording without consent, such as a public lobby, waiting area, or café.
- Sign consultant to verify with department if sign is required and to coordinate file delivery with the FP&D Sign Program Representative.

Placement

- Place adjacent to the affected room/area entrance or within the space in a visible position.
- If there is no wall space, alternate installation context is acceptable. To be displayed on a waiting room table, or registration desk in a acrylic insert holder.

Components

- Ⓐ Digital print on white letter size paper. Dotted lines represent visible window area, do not print.
 - Typeface: Proxima Nova Bold, Medium, Regular and Light
- Ⓑ See IN.10 Insert Holder, Letter Size for details
 - Vertical orientation.
- Ⓒ Acrylic Standing Sign Holder: Nu Dell item number 184624 or approved equal



Front View
Scale: 3"=1'-0"

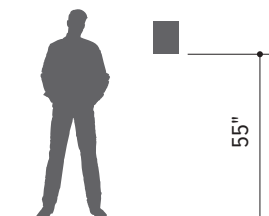

Installation Context,
Preferred
Scale: 3/16" = 1'-0"

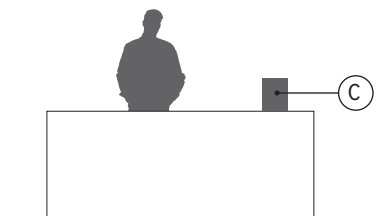

Installation Context,
Alternate
(use only if space not available)

Informational

IN.33

Video Surveillance

Usage

- This sign type is used to identify an area under video surveillance.

Placement

- Place adjacent to the affected room/area entrance or within the space in a visible position.

Components

- (A) Panel: 1/8" thick non-glare acrylic
 - Finish: subsurface painted
 - Sides: no paint with clean routed edges
- (B) Graphics: subsurface UV cured digital print
 - Typeface: Proxima Condensed Medium

Colors & Materials

References as noted below. See Chapter 1: Universal Standards for specifications.

(C1) White Wonder

(D3) PMS Cool Gray 10C

Installation

- See Appendix A, Drawing FD.10 for approved standard fabrication and installation detail.

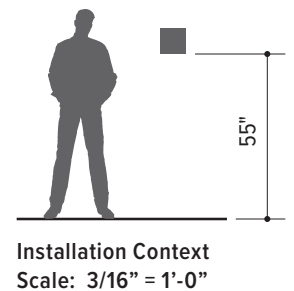

Informational

IN.34

Chicken Pox or Rash Warning

Usage

- This sign type is used to stop people with chicken pox or a rash from entering a room or area and to notify the receptionist.

Placement

- Place adjacent to the affected room/area entrance.

Components

- (A) Panel: 1/8" thick non-glare acrylic
 - Finish: subsurface painted
 - Sides: no paint with clean routed edges
- (B) Graphics: subsurface digital print
 - Typeface: Proxima Nova Condensed Regular and Semibold

Colors & Materials

References as noted below. See Chapter 1: Universal Standards for specifications.

- (C1) White Wonder (D3) PMS Cool Gray 10C (D6) Emergency Red

Installation

- See Appendix A, Drawing FD.10 for approved standard fabrication and installation detail.

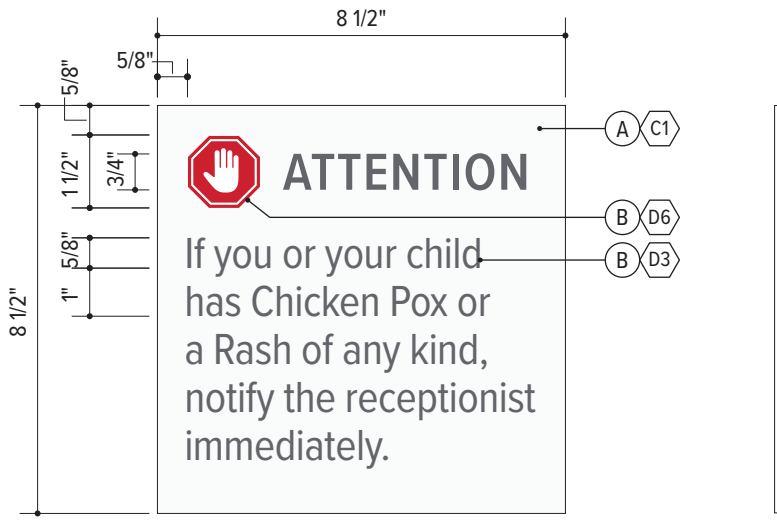

Front View
Scale: 3"=1'-0"

Side

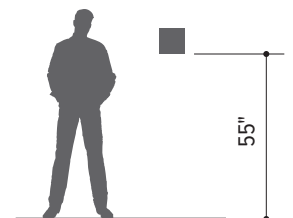

Installation Context
Scale: 3/16" = 1'-0"

Informational

IN.35

No Feeding the Squirrels

Usage

- This sign type is used to stop people from feeding squirrels.

Placement

- Place at key exterior locations where people are susceptible to feeding squirrels.

Components

- (A) Panel: 1/8" thick aluminum
 - Finish: painted all visible surfaces
- (B) Graphics: surface UV cured digital print with protective satin clear coat
 - Typeface: Proxima Nova Condensed Semibold

Colors & Materials

References as noted below. See Chapter 1: Universal Standards for specifications.

(C1) White Wonder (D3) PMS Cool Gray 10C (D6) Emergency Red

Installation

- See Appendix A, Drawing FD.10 for approved standard fabrication and installation detail.



Front View
Scale: 3"=1'-0"



Side

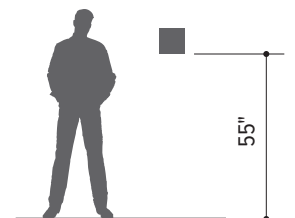

Installation Context
Scale: 3/16" = 1'-0"

Informational

IN.36

Take Personal Belongings

Usage

- This sign type is used to remind people to take their personal belongings before exiting.
- Use in patient dressing rooms.

Placement

- Place adjacent to the affected room/area's exit point or within the space in a visible position.

Components

- (A) Panel: 1/8" thick non-glare acrylic
 - Finish: subsurface painted
 - Sides: no paint with clean routed edges
- (B) Graphics: subsurface digital print
 - Typeface: Proxima Nova Condensed Regular and Semibold

Colors & Materials

References as noted below. See Chapter 1: Universal Standards for specifications.

- (C1) White Wonder (D3) PMS Cool Gray 10C (D6) Emergency Red

Installation

- See Appendix A, Drawing FD.10 for approved standard fabrication and installation detail.

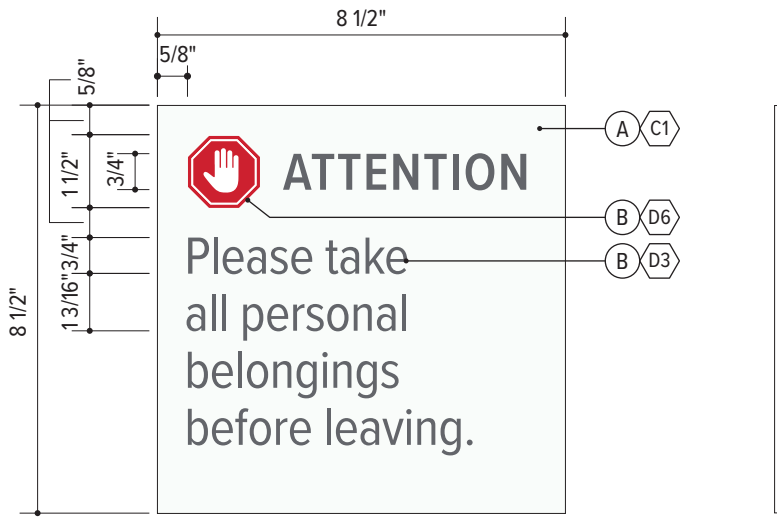

Front View
Scale: 3"=1'-0"

Side



Installation Context
Scale: 3/16" = 1'-0"